

# Intelligent Control of DSTATCOM for Voltage Sag Improvement Using Firefly Algorithm Optimized Fuzzy Logic Controller

**Absal Nabi and Dr. N Albert Singh**

*Research Scholar, EEE Department,  
Noorul Islam University Thucklay, Tamilnadu, India.*

*BSNL Executive BSNL Nagercoil, Tamilnadu, India.*

## Abstract

In this paper improvement in voltage sag by using firefly algorithm optimized fuzzy controller is described. DSTATCOM is the FACTS device used in voltage sag improvement. Firefly algorithm optimization is used to optimize the if-then rules of the fuzzy controller. In this system a DSTATCOM is placed in a three phase system to control the voltage sag. A fuzzy controller is designed to control the output of DSTATCOM. The whole system is simulated using MATLAB Simulink. The fuzzy controlled DSTATCOM output is compared with a PI controlled DSTATCOM output. The system without DSTATCOM is also simulated using MATLAB Simulink. The fuzzy controller rules are optimized using firefly algorithm and the results are also compared with other systems.

**Keywords:** Voltage sag, DSTATCOM, Fuzzy Logic, Optimization, Fuzzy Logic Controller, Firefly Algorithm

## Introduction

Power quality is a set of electrical boundaries that allows an equipment to perform in its specified manner. Voltage sag and voltage swell are the common power quality issues. Voltage sag is defined as a decrease in voltage to between 0.1 and 0.9 pu in rms voltage for a duration of 0.5 cycle to 1 minute [2]. Voltage sag occurs mainly due to faults and the short circuit current results in decrease of voltage [6]. Graphical representation of voltage sag is shown in Fig. 1. Here we consider voltage sag due to

three types of faults namely single line to ground fault (SLG), double line to ground fault (DLG), and three phase fault.

As the demand of electric power is increasing day by day, the transmission networks are found to be very weak so that they cannot supply unreliable supply with good quality. Flexible A transmission systems (FACTS) is an idea developed based on power electronic controllers, which controls the values of different electrical parameters. FACTS technology makes use of high speed thyristors for switching in or out transmission line components for the required performance of the system. There are different types of FACTS devices namely shunt connected devices and series connected devices [1].

DSTATCOM is a shunt connected FACTS device. It is a reactive source that can be controlled and it is capable of absorbing or generating reactive power. DSTATCOM consists of coupling transformer, voltage source converter, DC energy storage device and necessary control circuits [8].

The DSTATCOM can provide compensation in both inductive and capacitive mode. The V-I characteristic of DSTATCOM is shown in figure. By using DSTATCOM we can control the effect of voltage sag also.

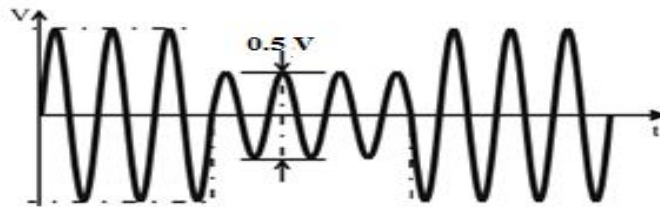

**Figure 1:** Graphical Representation of Voltage Sag

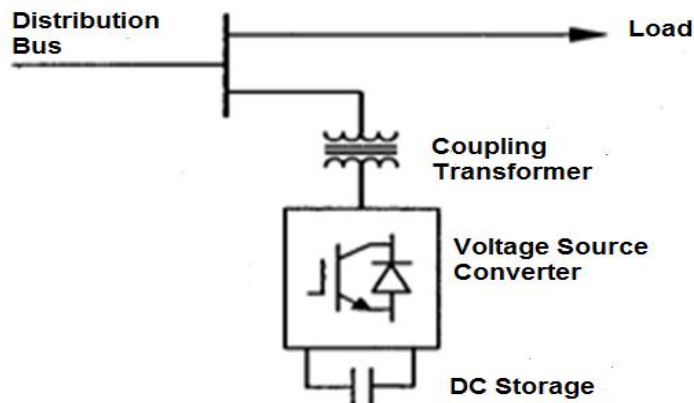
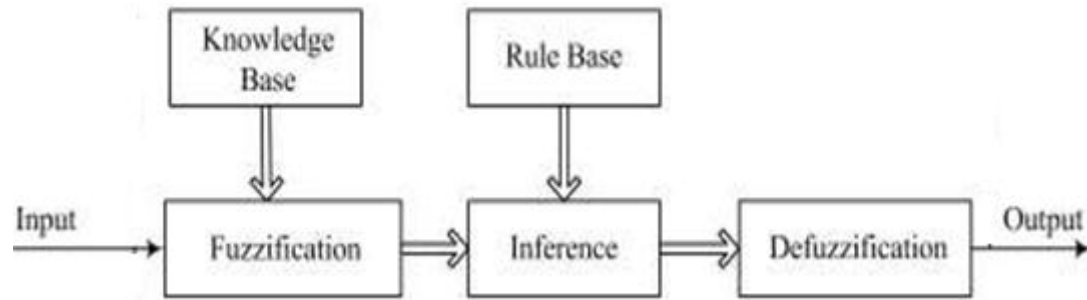

**Figure 2:** Block Diagram of DSTATCOM

Intelligent control techniques provide a method of approximate reasoning that is similar to human decision making process. They have fast response time and high range of operating conditions. Fuzzy logic provides a formal idea for presenting and

implementing human knowledge about how to control a system [3]. The fuzzy logic controller is shown below.

Fuzzification part converts crisp input values into fuzzy values. The knowledge base consists of a database of the plant. It gives all the required definitions for the fuzzification process. Rule base represents the controlling system of the network. It is represented as a set of if-then rules. Inference applies fuzzy reason to rule base to obtain the output. Defuzzification process converts fuzzy output to crisp values.



**Figure 3:** Fuzzy Logic Controller

### DSTATCOM Control Scheme

DSTATCOM is controlled by means of PWM generator. The test system output is compared in an error detector and its output is fed to a fuzzy logic controller. The controller will take necessary control actions and the controller will output an angle  $\delta$  which is phase modulated by the following equations [5].

$$V_A = \sin(\omega t + \delta) \quad (1)$$

$$V_B = \sin(\omega t + \delta - 2\pi/3) \quad (2)$$

$$V_C = \sin(\omega t + \delta + \pi/3) \quad (3)$$

The phase modulated signals are fed to PWM generator and the pulses from PWM generator will control the operation of DSTATCOM during voltage sag.

### Design of Fuzzy Logic Controller

The fuzzy logic controller designed here consists of two inputs, namely error and change in error, and an output [7]. Seven linguistic variables are selected. The linguistic variables are NEB, NEM, NES, ZE, POS, POM and POB. Triangular shaped membership functions are chosen for the inputs and output. A rule base with strength of forty nine rules is created by interconnecting different variables. Fuzzy logic controller is implemented by using fuzzy logic toolbox of Matlab Simulink.. The rule base for inputs and output using different linguistic variables are given in the table below

**Table 1:** Fuzzy Logic Rulebase

de e	NEB	NEM	NES	ZE	POS	POM	POB
NEB	NEB	NEB	NEB	NEB	NEM	NES	ZE
NEM	NEB	NEB	NEB	NEM	NES	ZE	POS
NES	NEB	NEB	NEM	NES	ZE	POS	POM
ZE	NEB	NEM	NES	ZE	POS	POM	POB
POS	NEM	NES	ZE	POS	POM	POB	POB
POM	NES	ZE	POS	POM	POB	POB	POB
POB	ZE	POS	POM	POB	POB	POB	POB

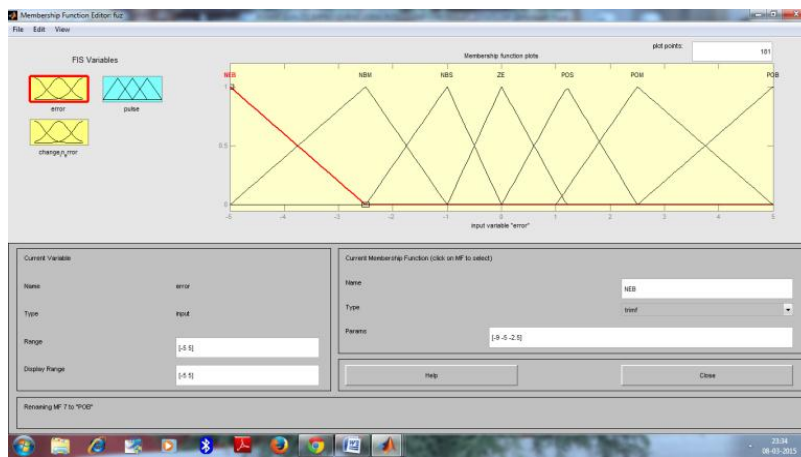

**Figure 4:** Membership function for input

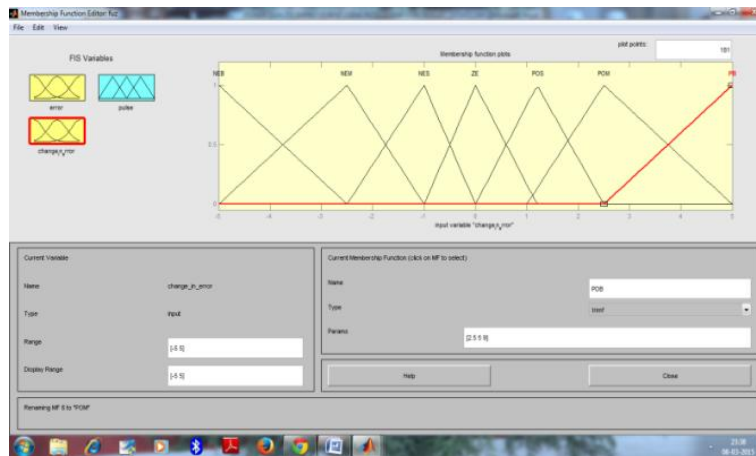

**Figure 5:** Membership function for input2

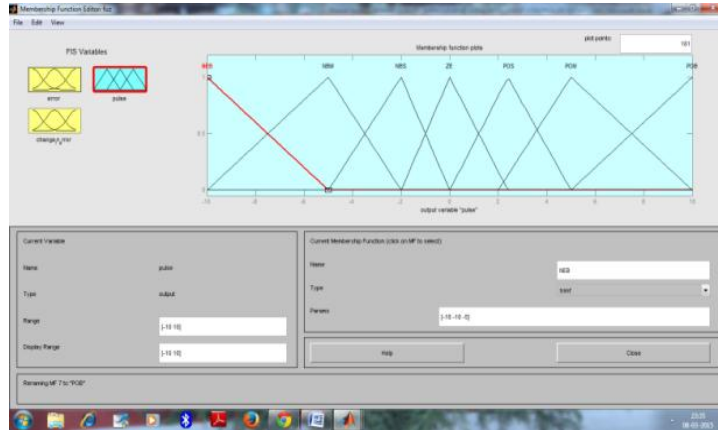

Figure 6: Membership function for output

### Optimization Using Firefly Algorithm

The biological process of producing a flashing light is called bioluminescence. The insects which produce light by means of this process are called fireflies. For attracting the female fireflies, the male fireflies produce this flashing light. Mainly the flashing lights are to communicate with their partners. Firefly algorithm (FA) is a metaheuristic algorithm based on natural process. This algorithm is inspired by flashing of fireflies to attract their mates. The firefly algorithm has been proved efficient in solving different complex optimization problems[9]. The objective function in the algorithm is equivalent to the brightness of the firefly. The brightness decreases with an increase in distance from the light source.

Three main assumptions in firefly algorithm are[10]

1. Regardless of sex a firefly is attracted by all other fireflies.
2. A firefly with less brightness is attracted towards a firefly with high brightness. If there is no brighter or more attractive firefly than a particular one, then it will move randomly.
3. Fitness function landscape depends on light intensity.

We can determine the attractiveness of a fire fly by the equation (4)

$$\beta = \beta_0 e^{-\gamma r^m} \tag{4}$$

where  $\beta_0$  is the attractiveness at  $r=0$

$\gamma$  is the coefficient of absorption

The Cartesian distance between any two fireflies  $i$  and  $j$  at positions  $x_i$  and  $x_j$  is determined by the equation (5)

$$r_{ij} = \sqrt{\sum_{k=1}^d (x_{i,k} - x_{j,k})^2} \tag{5}$$

The movement of a firefly is determined by the equation (6)

$$x_i = x_i + \beta_0 e^{-\gamma r^2} (x_j + x_i) + \alpha \epsilon \tag{6}$$

where  $\alpha$  is the parameter of randomization and  $\epsilon$  is a random number

The firefly algorithm can be explained by the following steps[11]

1. Define the objective function
2. Create initial population
3. Calculate light intensity  $l_i$
4. Select absorption coefficient  $\gamma$
5. for  $i=1$  to  $n$  (where  $n$  is the total number of fireflies)
6. for  $j=1$  to  $n$
7. If we have  $l_j$  greater than  $l_i$  then move  $i$ th firefly towards  $j$ th firefly
8. Analyse new values and update light intensity
9. End  $j$  loop
10. End  $i$  loop
11. Rank the fireflies and find the best among them
12. Repeat the process from step 3 till the iterations are completed.

The new optimized rule base of fuzzy logic controller is given in Table 2

### Test System

Test system consists of a 250kv source which is connected to the input of a three phase three winding transformer. The output terminals of three phase tree winding transformer are fed to two branches of 11kv each. In one of the branches DSTATCOM is connected for the compensation of voltage sag is connected. In the second feeder we connected linear and varying loads. Different faults are introduced into this branch and the test results are analysed.

**Table 2:** Optimized Fuzzy Logic Rule Base

e de	NEB	NEM	NES	ZE	POS	POM	POB
NEB	NEB	NEB	NEB	NEM	NES	NES	NES
NEM	NEB	NEM	NEM	NES	NES	NES	NES
NES	NES	NES	NES	NES	NES	NEM	NEM
ZE	NES	NES	ZE	ZE	ZE	ZE	ZE
POB	POS	POS	POS	POS	POS	POS	POS
POM	POS	POS	PO	POM	POM	POM	POB
POB	POS	POS	POM	POM	POB	POB	POB

### Simulation Results

The system is simulated using Matlab Simulink Sim Power Systems toolbox.

A three phase fault is applied for a time range 0.85s-0.9s with a fault resistance of 0.66Ω. The system is simulated for 1s. In the first case no DSTATCOM is placed for the compensation of voltage sag. In the second case DSTATCOM with PI controller is introduced in the system. In the third case fuzzy controlled DSTATCOM is

operated during the time of fault. In the last stage particle swarm optimized fuzzy logic controller is provided. A subsystem block is also provided in SIMULINK model to generate the PWM control signals. MATLAB Simulink test model and the simulation results are shown below. During the fault in the system without DSTATCOM, a voltage sag occurs and there is no control over the system. When PI controlled DSTATCOM is placed in the system voltage sag is mitigated. Fuzzy controlled DSTATCOM provides much more improvement in voltage sag mitigation. The optimization of fuzzy controller gave much more improved result. From the various figures given below we can analyse the performance of different controllers.

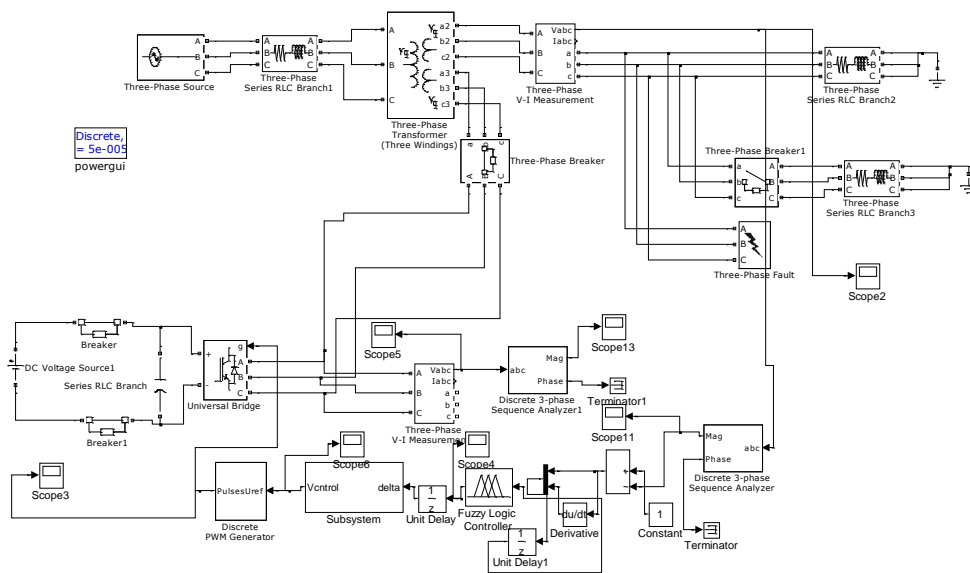

Figure 7: Simulink Model of the Test System

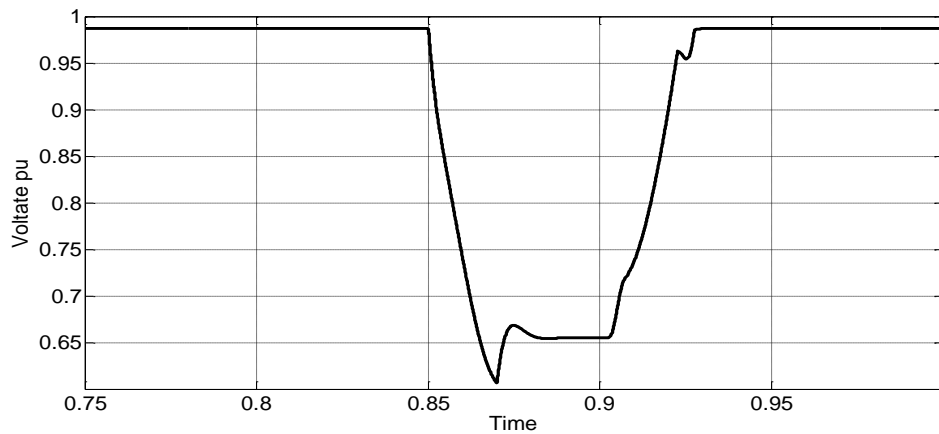
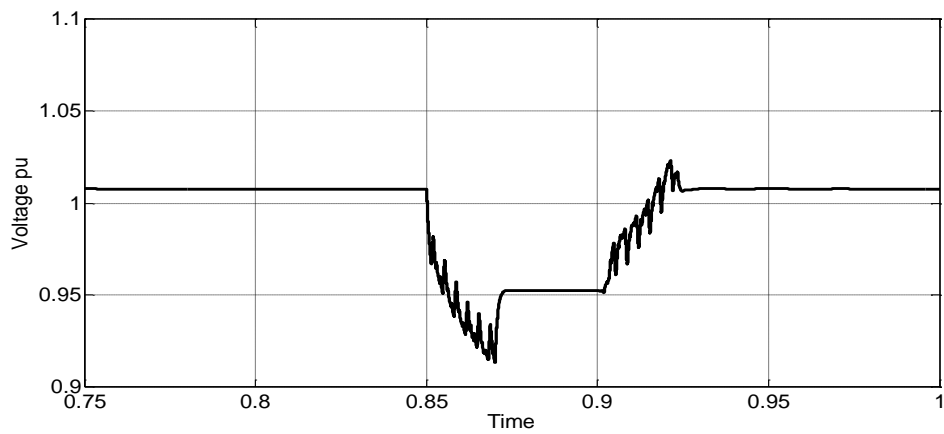
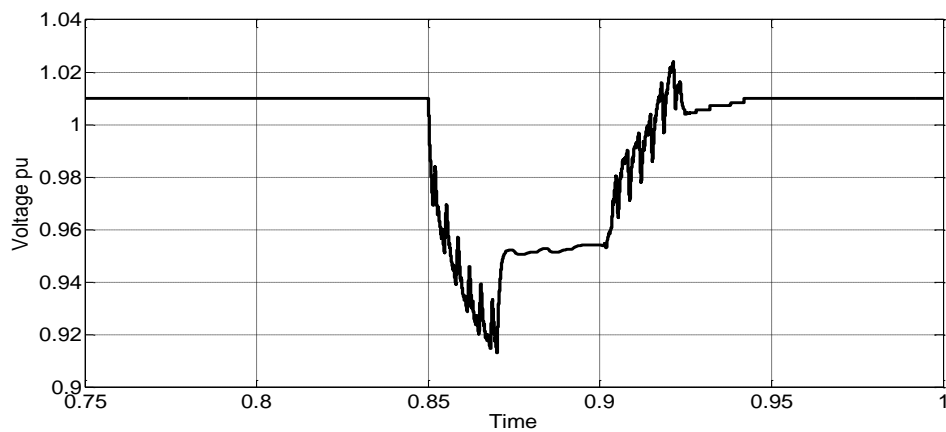

Figure 8: Output of the System without DSTATCOM in the system



**Figure 9:** Output of the System with PI Controlled DSTATCOM in the system



**Figure 10:** Output of the System with Fuzzy Logic Controlled DSTATCOM

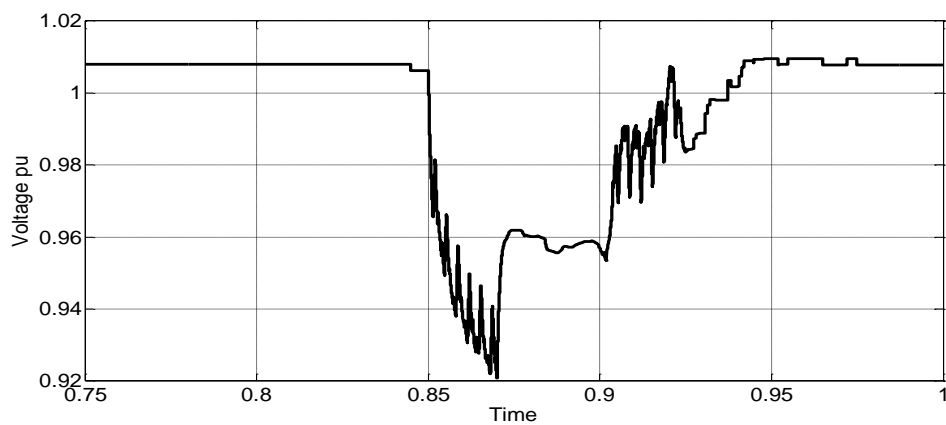

**Figure 11:** Output of the System with Firefly Algorithm Optimized Fuzzy Logic Controlled DSTATCOM



## Conclusion

From the test results we can see that performance of fuzzy controlled DSTATCOM is better than the performance of PI controlled DSTATCOM. During Voltage sag, the magnitude of voltage output of Fuzzy controlled DSTATCOM is higher than that of PI controlled DSTATCOM and it is further increased by firefly algorithm optimization. Firefly algorithm optimized fuzzy controlled DSTATCOM can perform well in voltage sag mitigation. A combination of different intelligent control techniques can be applied for the control of DSTATCOM. The performance of DSTATCOM can be further improved by the application of hybrid optimization techniques.

## References

- [1] Rajesh Gupta, Arindam Ghosh and Avinash Joshi, "Performance Comparison of VSC Based Shunt and Series Compensators Used for Load Voltage Control in Distribution Systems, " *IEEE Transactions On Power Delivery*, Vol. 26, No. 1, January 2011
- [2] Yan Zhang and Jovica V. Milanovic, "Global Voltage Sag Mitigation With FACTS-Based Devices, " *IEEE Transactions On Power Delivery*, Vol. 25, No. 4, October 2010
- [3] S. Mishra, P. K. Dash, P. K. Hota, and M. Tripathy, "Genetically Optimized Neuro-Fuzzy IPFC for Damping Modal Oscillations of Power System, " *IEEE Transactions On Power Systems*, Vol. 17, No. 4, November 2002
- [4] M. Vishnuvardhan and Dr. P. Sangameswararaju, "Neuro-Fuzzy Controller and Bias Voltage Generator Aided UPQC for Power Quality Maintenance, " *International Journal of Computer Theory and Engineering*, Vol. 4, No. 1, February 2012
- [5] Bhattacharya Sourabh, "Applications of DSTATCOM Using MATLAB/Simulation in Power System, " *Research Journal of Recent Sciences*, Vol. 1(ISC-2011), 430-433 (2012 )
- [6] Jovica V. Milanovic, Fellow, IEEE, and Yan Zhang, "Modelling of FACTS Devices for Voltage Sag Mitigation Studies in Large Power Systems, " *IEEE Transactions On Power Delivery*, Vol. 25, No. 4, October 2010
- [7] F. Valdez, P. Melin, O. Castillo, "An improved evolutionary method with fuzzy logic for combining Particle Swarm Optimization and Genetic Algorithms". *Appl. Soft Comput.* 11(2): p. p. 2625-2632, 2011.
- [8] Bhim Singh,, P. Jayaprakash, Sunil Kumar, and D. P. Kothari, "Implementation of Neural-Network-Controlled Three-Leg VSC and a Transformer as Three-Phase Four-Wire DSTATCOM , " *IEEE Transactions On Industry Applications*, Vol. 47, No. 4, July/August 2011
- [9] F. Valdez, and P. Melin, "Parallel Evolutionary Computing using a cluster for Mathematical Function Optimization", *Nafips*. San Diego CA, USA, p. p. 598-602, June 2007.

- [10] X. S. Yang, "Firefly Algorithms for Multimodal Optimization", in Proceedings of the Stochastic Algorithms: Foundations and Applications (SAGA '09), Vol. 5792 of Lecture Notes in Computing Sciences, Springer, Sapporo, Japan, October 2009, pp. 178-178.
- [11] T. S. Gorripotu, R. K. Sahu and S. Panda, "Application of Firefly Algorithm for AGC Under Deregulated Power System", Computational Intelligence in Data Mining, Vol. 1, Smart Innovation, Systems and Technologies Vol. 31, 2015, pp. 677-687