

## **Industrial Automation System**

**K. Madhanamohan!, R.K. Praveen\*, T.R. Nirmalraja\*, H. Goutham\*,  
R. Sabarinathan\* and A. Logeesan\***

*!Sri Sairam Engg College.*

*\*Sri Sairam Engg College.*

### **Abstract**

This paper describes how the present automation system comes in to existence through its various stages. In the past, system is done through relays and contactor logics. Since the human intervention is more, the scope of errors was also more. But with the advent of microprocessors several new tools as PLC's, SCADA, and DCS come in to use. These have reduced human intervention, which in turn has increased accuracy, precision and efficiency. A comparative study has been shown to justify why we have to switch to present technologies.

### **1. Introduction**

Automation is the key to modernization and has been conceptually understood as a way to increase efficiently and to improve productivity. The process of having machine follow a predetermined sequence of operation with little or no human labor, using special equipment and devices that perform and control manufacturing processes is known as automation. The goals of automation are Integration of various aspects of manufacturing operations to reduce labor cost, To improve productivity or efficiency, To improve quality, To reduce human involvement therefore human error, To reduce work piece damage that manual handling caused, To raise the safety level. The fundamental constituents of any automated process are (1) a power source, (2) a feedback control mechanism, and (3) a programmable command (as shown in figure structure. For example, an automated car wash typically completes its task with no continuous or final assessment of the cleanliness of the automobile.

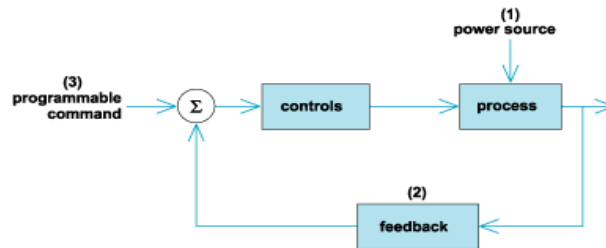

Figure. 1

## 2. Automation Tools

- Relays and contactor logic
- Programming logic controllers (PLC)
- Supervisory control and data acquisition (SCADA)
- Distributed control system (DCS)

### I (a) RELAY SYSTEM

A relay is an electrical switch that opens and closes under control of another electrical circuit. In the original form, the switch is operated by an electromagnet to open or close one or many sets of contacts. The general functions of relays are protection, monitoring and control. If the coil is energized with DC, a diode is frequently installed across the coil, to dissipate the energy from the collapsing magnetic field at deactivation, which would

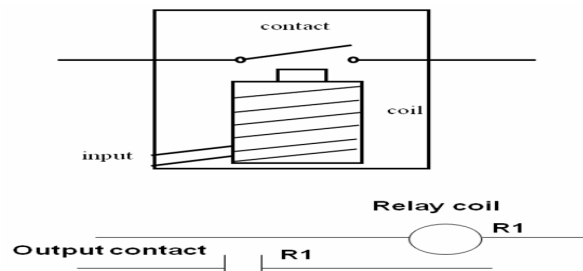

Figure. 2

otherwise generate a spike of voltage and might cause damage to circuit components.

### Disadvantages of Relay System

1. The maintenance cost of the relay system is quite high, as the frequent maintenance is required in it.
2. A driver circuit is required along with larger relays.
3. Very high human intervention is required in this system.

4. They do not allow manual adjustment of the relay state when the control power is off.
5. These are only use for ON/OFF control.
6. Intermediate controlling is not possible by the relays.

### I (b) Contactor Logic

A contactor is an electrically controlled switch (relay) used for switching a power circuit. A contactor is activated by a control input which is a lower voltage / current than that which the contactor is switching. Contactors come in many forms with varying capacities and features. Unlike a circuit breaker a contactor is not intended to interrupt a short circuit current. A contactor is composed of three different systems. The contact system is the current carrying part of the contactor. This includes Power Contacts, Auxiliary Contacts, and Contact Springs. The electromagnet system provides the driving force to close the contacts. The enclosure system is a frame housing the contact and the electromagnet. Open-frame contactors may have a further enclosure to protect against dust, oil, explosion hazards and weather. The major disadvantage of relays and controller logic is that it does not have any redundant system it means that if system fails then, it does not have any controlling system to continue its controlling and monitoring process.

## 3. Programming Logic Controller

A digitally operating electronic apparatus which uses a programmable memory for the internal storage of instructions by implementing specific functions such as logic sequencing, timing, counting, and arithmetic to control, through digital or analog input/output modules, various types of machines [1]. Architecture of PLC is shown in figure 3.

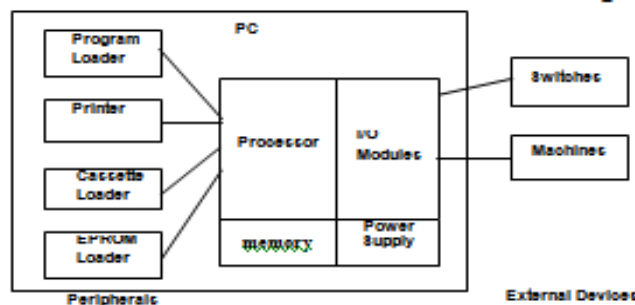

Figure 3.

- 1) 1) Programmable Memory- The instruction for logical control sequence is stored here.

- 2) Data Memory- The status of the switches interlocks, past values of data and other working data is stored here.
- 3) O/P Devices- These are hardware or software drives for industrial process actuators, such as solenoid, switches, motor and valves.
- 4) I/P Devices- These are hardware or software driver for industrial process sensors such as switch status sensors, proximity detectors interlock setting.

#### 4. Working principal of PLC

Ladder logic programming method is used for working of PLCs. In this logic the power is on vertical line on the left hand side, on the right hand side is the neutral rail as in the figure 4 there are two rungs and on each rung there are combination of input and output, if the input are open or closed in the right combination

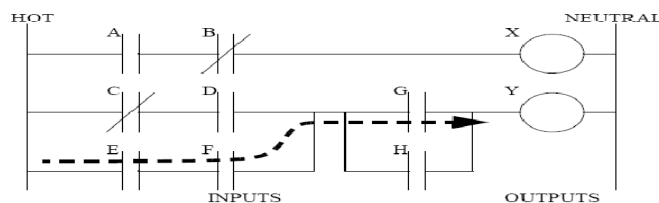

Figure. 4

the power can flow from the hot rail through the inputs to power the output and finally to the neutral rail. An input come from a sensor and output will be some devise outside the Plc,

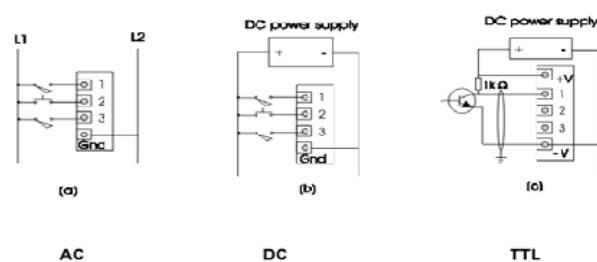

Figure. 5: Input Connections

That is switched on or off such as motor, in the top rung the contacts are normally open (NO) or normally closed (NC). Which means if input a is on and b is off the power will flow through the output and activated. Any other combination of input values will result in the output x being off [2]. The input connections (figure.5 ), and output connections ( figure.6 ) are shown.

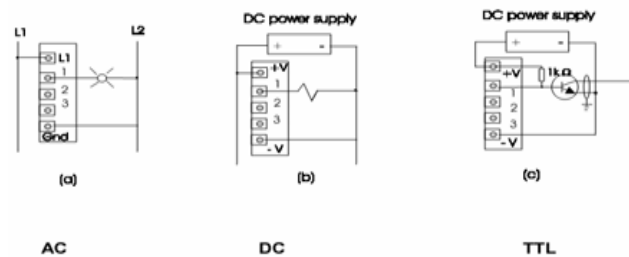

Figure. 6: Output Connections.

### Scanning Principle of PLC

A PLC resolves the logic of a ladder diagram (program) rung by rung, from the top to the bottom. Usually, all the outputs are updated based on the status of the internal registers. Then the input states are checked and the corresponding input registers are updated.

Only after the I/Os have been resolved, is the program then executed. This process is run in an endless cycle. The time it takes to finish one cycle is called the scan time. In some controllers the idle state is eliminated. In this case, the scan time varies depending on the program length. Advantages Of Using Plc's are as follows:

- 1) Cost effective for controlling complex systems.
- 2) Flexible and can be reapplied to control other systems quickly and easily.
- 3) Computational abilities allow more sophisticated control.
- 4) Trouble shooting aids make programming easier and reduce downtime.

## 5. SCADA

SCADA is an acronym that stands for Supervisory Control and Data Acquisition. SCADA, a computer system, for gathering and analyzing real time data. SCADA systems are used to monitor and control a plant or equipment in industries such as telecommunications, water and waste control, energy, oil and gas refining and transportation [3],[4]. Component used in SCADA are as follows:

**1. Remote Terminal Unit (RTU):-** RTU is a device installed at a remote location that collects data, codes the data into a format that is transmittable and transmits the data back to a central station, or master. An RTU also collects information from the master device and implements processes that are directed by the master.

**2. Master Terminal Unit (MTU):-** The term "Master Station" refers to the servers and software responsible for communicating with the field equipment (RTUs, PLCs, etc), and then to the HMI software running on workstations in the control room, or elsewhere.

**3. Field Instrumentation:-** It refers to the devices that are connected to the equipment or machines being controlled and monitored by the SCADA system[5]. These are sensors for monitoring certain parameters; and actuators for controlling certain modules of the system.

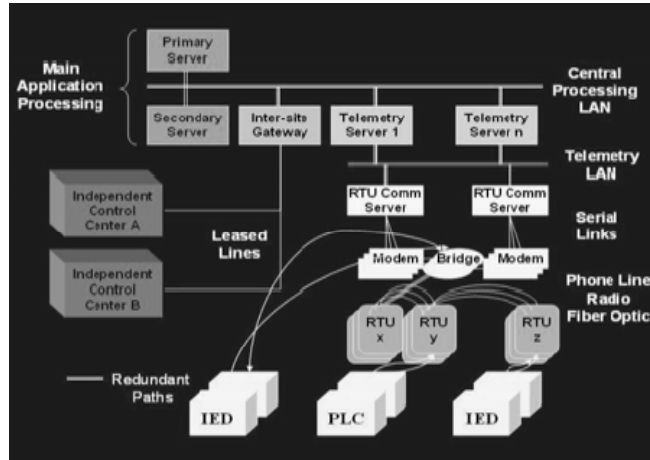

**Figure 8:** SCADA System and IT'S Component.

**4. Communication Network:-** Communication network refers to the communication equipment needed to transfer the data to and from different sites to the central station. The medium used can either be cable or telephone. Remotes are usually not Accessible by telephone lines. The use of radio offers an economical solution. Modems are used to connect the remote sites to the host [6]. In the SCADA for the controlling operation there are basically three types of configuration used for all types of control measurement. They are as follows:-

- 1) Point To Point control system configuration.
- 2) Point To Multipoint control system configuration.
- 3) Peer To Peer control system configuration.

### HMI system in SCADA

A SCADA system includes a user interface, usually called Human Machine Interface (HMI). The HMI of a SCADA system is where data is processed and presented to be viewed and monitored by a human operator. This interface usually includes control where the individual can interface with the SCADA system [7].

### Limitation of SCADA system:-

Real-time information on the system is required to affect improved, speedier and more accurate switching [7]. Most utility organizations have SCADA systems in place (to varying degrees of complexity and depth into the system). SCADA provides data concentration and remote switching. SCADA does not provide complete information concentration (having been designed for transmission and grid systems). Where as in distributed control system central processing is distributed through system which makes it's controlling & monitoring fast & accurate. It provides complete and reliable information concentration.

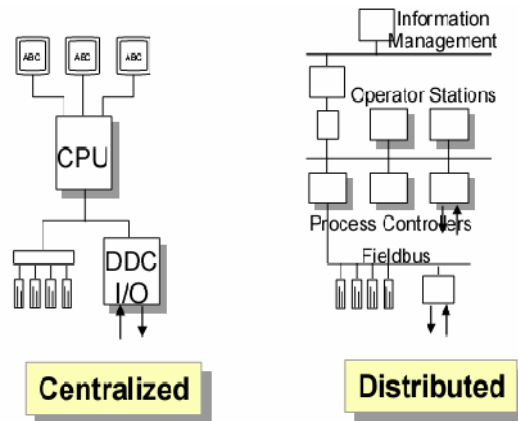

**Figure.10:** Comparison b/w SCADA and DCS.

## 6. Distributed Control System

A distributed system refers to a control system usually of a manufacturing system, process or any kind of dynamic system, in which the controller elements are not central in location (like the brain) but are distributed throughout the system with each component sub-system controlled by one or more controllers[8,9].

### Architecture of DCS

#### 1) Engineering Workstation

The Engineering Workstation (EWS) is for project development, including configuration of graphics, logic, alarms, security, etc. Typically, the EWS is a PC running Windows 2000/XP.

#### 2) Process Historical Archivers

The Process Historical Archives' (PHA) stores and retrieves historical data collected by the FCU, micro FCU, SDS, or any other intelligent device in the system. The PHA can run standalone or can share an OWS workstation.

#### 3) Controllers

The Field Control Unit (FCU) executes sequential and regulatory logic and directly scans I/O. Depending on the FCU's configuration, you can scan multiple brands of I/O from one unit. The FCU runs QNX, a realtime operating system, and is typically a PLC industrial computer.

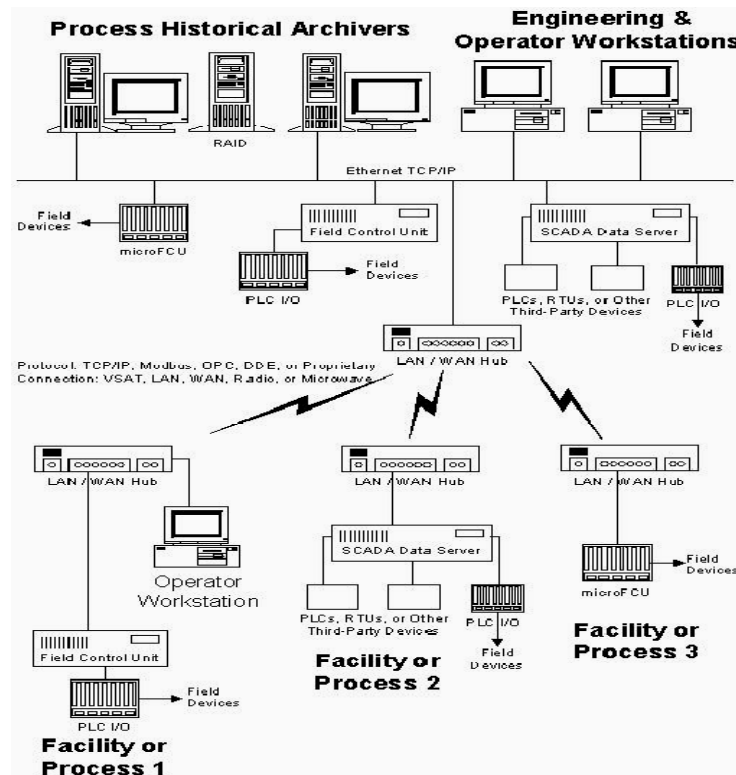

Figure 11: ARCHITECTURE OF DCS.

#### 4) Networking and Communications

UCOS supports redundant and non-redundant fiber optic and Ethernet local networks using the TCP/IP networking protocol for standardized, advanced application connectivity.

#### Advantages of using DCS [10]

- 1) Modular and Scalable
- 2) Easy Implementation
- 3) Plug And Play
- 4) Reliability
- 5) Limited Distributed Intelligence
- 6) Less Cabling

#### 7. Conclusion

This paper discusses the control schemes for industrial automation and system monitoring to improve system operation, system reliability, asset management, etc. Various types of automation system such as relays, contactor logic, PLC's, SCADA



and DCS has been discussed and we have concluded that the new DCS, SCADA, and communication systems make it possible to integrate protection, control and monitoring together to its maximum benefits. The innovative development of automatic switching will yield more benefits to distribution utilities. Truly, distribution automation and system monitoring are the logical choice for the utilities to improve system performance, and to achieve customers and shareholders satisfactions.

## References

- [1] D.E.Seborg, T.F.Edgar, D.A. Melichamp process dynamic and control, wiley, 1989
- [2] G.Warnock, programmable controller: operation and application, prentice hall, 1988
- [3] Author: Lester Abbey managing ctor Abbey System Presented: Inaugural New Zealand SCADA Conference 28-29 October 2003, Auckland, NZ
- [4] HISTORY OF SCADA, (by Randy Dennison, EPG Companies Inc.) Sponsor "Energy Development and Power Generation Committee of the IEEE Power Engineering Society" The Institute of Electrical and Electronics Engineers, Inc. 345 East 47th Street, New York, NY 10017-2394, USA
- [5] Joe mullaney .Senoiri&c engineer, MSE technology Applications, INC. , Tetragenics Division
- [6] G.Baribaud et al., "Recommendations for the Use of Field buses at CERN in the LHC Era", Proceedings of the 1997 International Conference on Accelerator and Large Experimental Physics Control Systems, Beijing, 1997, p.285.
- [7] People in Control: An International Conference on Human Interfaces in Control Rooms, Cockpits and Command Centers 21 - 23 June 1999, Conference Publication No. 463, O IEE, 1999.
- [8] Tabisz, Jovanic, & Lee,; "Present and Future of Distributed Power Systems," APEC Proceedings, February 1992.
- [9] Gordon Clarke, peon Reyenders ,Edwin Wright Practical Modern SCADA Protocol , proceedings of IEEE, newness 2004.
- [10] Bretz, E.A. "By-Wire cars turn the corner" IEEE Spectrum ,Vol. 38, no. 4, pp.68-73 , april 2001.

