

Interfacing of Automatic Gas Control Unit with Atomic Absorption Spectrophotometer via PC

¹Gnana Tejaswi punukollu and ²Dileep Chappidi

*Department of Electronics and Communication Engineering
Hyderabad Institute of Technology and Management, Hyderabad, AP India
E-mail: gnanatejaswi@ieee.org, diliprathan@ieee.org*

Abstract

The spectrophotometer is an instrument which is concerned with identification and measurement of organic compounds and is called the work house of modern laboratory.

Atomic Absorption Spectrophotometer (AAS) is an electro-optical – mechanical instrument used to determine the Absorbance of different samples in the form of liquids at different wavelengths of light in the Electromagnetic spectrum [1]. The analysis of different elements like Copper, Iron, Zinc, Lead, etc is done by measuring the absorbance of a sample, atomized in a flame. Based on the absorbance and transmittance we can fine out the concentration of a particular metal in a sample.

The main objective is of this project is to Controlling instrument parameter like wavelength, lamp current selection, EHT variation, Indexing and Peak operation. Reading, storing values from instrument, data analysis, plotting graphs, auto - gas control and Report Generation We can operate AAS through micro-controller module which performs all the functions same as the PC unit

Introduction

The “Atomic Absorption Spectrophotometer (AAS)” is an electro optical – mechanical instrument used for absorption and emission analysis as shown in figure 1. It is used to determine the absorbance of different samples, in the form of liquids at different wavelengths of light in the electromagnetic spectrum by atomizing them in a flame. This is based on the principle of atomic absorption spectroscopy. Instruments used to study absorption or emission magnetic radiation as a function of wavelength are known as spectrophotometer[1].

The basic operation involves the atomization of the sample solution by burning it along with fuel gas in the flame. Atomic absorption spectroscopy may be defined as

a method for determining the concentration of an element in a sample by measuring the intensity of external radiation absorbed by atoms produced from a sample at a wavelength characteristic for that element. Soil scientists have used petrochemical methods to determine elemental contents of soil digests, soil extracts and plant digests for many years. Early research related elemental soil content with measurement of essentials plant nutrients to determine their soil chemistry and to make appropriate fertility recommendations. Atomic absorption is a preferred technique in many analytical situations such as Environmental, metallurgical, research, educational, clinical, petrochemical etc... [5]

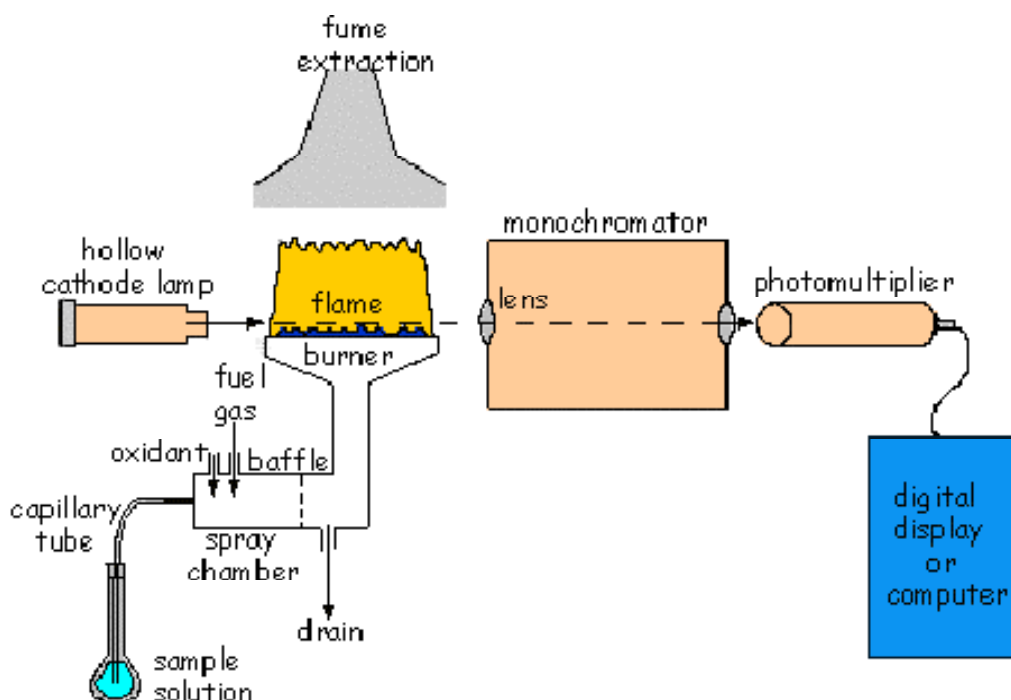

Figure 1: A schematic diagram of atomic absorption spectrometer

Description of Project

Atomic Absorption Spectrophotometer, AAS 4141 is a PC based Instrument for absorption and emission analysis. It is used for Quantitative elemental analysis mainly like Copper, Iron, Zinc, Lead etc., by measuring the absorbance of a sample atomized in a flame. Some of the metals like Sodium, Potassium, Calcium, and Lithium are analyzed by Emission method. Atomic absorption is preferred technique analytic solutions such as environmental, metallurgical, research, educational, clinical, petrochemical, etc.... The data processing and partial control of the instrument are done by PC [3]. The liquid sample is nebulised (reduced to a spray) by the support gas. The fuel gas is mixed and burnt over the burner head. A modulated light from Hollow Cathode lamp of a pre-selected element is split into two beams, a Sample and a Reference beam [6]. The Sample beam travels through the flame while the Reference

beam travels around it, and these two beams are re-combined before entering the Monochromator by a rotating chopper mirror. The Monochromator selects the appropriate resonance line of the selected element and directs it on to the PMT. The electronics thereafter, separates the sample and reference signals, which are separated in time with the help of SYNC signal from chopper [8]. The DC signal generated by the Flame Emission is rejected by FE compensation circuit and the original Signal of the lamp is amplified, phase sensitively rectified, averaged by an integrator to obtain sample signal and reference signal. The reference signal is used to compensate for the drifts in lamp intensities. The sample signal is processed for Photometric computations (%T, ABS or CONC) by an IBM PC. Instrument controls like Gas control, Wave-length, Lamp current, Gain etc., are achieved by PC. The Cathode material of Hollow Cathode Lamp corresponds to the element of Interest [4].

The Data analysis and Report making is done by the PC including Selection of Instrument parameters like Wavelength, Lamp Current selection, and EHT to PMT at various wavelengths. The software is user friendly window based GUI interface using menus, function keys, prompts, error messages, enabling ease of operation. Information is presented in easy read menus. In most cases recommended values are filled in.

The Instrument can be Calibrated using Regression Techniques of Linear and Quadratic methods against Standard Solutions and Concentration of unknown samples can be quantified. Instrument parameters and Calibration parameters can be stored as Applications which can be retrieved as and when required [2]. A hard copy of the results can be taken with the aid of a printer connected to one of the parallel ports of the PC.

Description of Automatic Gas Control Unit

Flame conditions are automatically setup as different methods are selected for any elemental analysis. Once flow and flame type details are transmitted to the instrument, the flame is established using an Air/Acetylene gas mixture. The gas control unit automatically drives the flow control needle valves and energises the solenoid valves as required. Instrument operator as only to ensure the correct burner is placed and all connections are proper and then enable IGNITE [3].

To set the desired mixture and acetylene and oxidant operator can adjust the flow control knobs of fuel and oxidant flow meters available on the front panel of the gas control box. Safety precautions are established for any default conditions and power failure. Flame is automatically put OFF under these conditions. An emergency switch is provided on gas control unit to put off the flame in any emergency condition [7].

Operating Instructions

Front Panel:

It consists of four function keys, one push button switch and eleven indicating LED's. There are four functional keys namely IGNITION, SHUT OFF, AIR/C₂H₂, N₂O/C₂H₂.

Ignition Key

This key enables to start automatic ignition sequence after all interlocks are cleared. A small green LED under this key ensuring that all interlocks are cleared. When ignition status LED is ON, pressing this key initiates the flame sequence (AIR/C₂H₂) according to the burner. Ignition can be enabled parallels with PC also.

Shut off Key

Pressing this key will shut off the flame. If any default conditions occur in any interlock, the software programmed automatically shuts off the flame. Shut off condition is indicated with a small RED LED. Shut- off can be enabled parallely with PC also.

AIR/C₂H₂ KEY

A small green LED under this switch indicates initialization of AIR/C₂H₂ flame, when air/acetylene burner is used and ignition is enabled.

N₂O/C₂H₂ Key

A small green LED under this switch indicates initialization of N₂O/C₂H₂ flame, when N₂O/Acetylene burner is used and ignition is enabled. When N₂O/C₂H₂ burner is placed and Air/Acetylene triggered, if N₂O/Acetylene flame required, by pressing this key boost and an N₂O change over takes place [9].

Emergency Shut off Push Button Switch

Pressing this switch in emergency condition, shut off flame Emergency switch also provides protective over ride shut down.

Function Status Led's

- **IGNITION:** This LED glows indicating the gas box is ready for ignition.
- **AIR/C₂H₂:** This LED glows indicating the AIR/C₂H₂ flame mode.
- **N₂O/C₂H₂:** This LED glows indicating the N₂O/C₂H₂ flame mode.
- **SHUT OFF:** This LED glows indicating the shut off sequence of the gas box.
- **MAINS ON LED:** This LED glows whenever AAS unit is switched ON.

Rear Panel

- 24 Pin shell connector inter connects all external sensors and solenoids from gas box to gas control unit.
- 3 pin round shell socket for main power.
- Fuse holder houses 3A fuse for the unit.
- 2 No's of socket provides 6V AC to glow plug filament.
- 9 pin Connector provides parallel interconnection for PC operation.
- Power transistor and diodes or mounted on a heat sink.

Operation of AGC: Auto gas control system can be operated in three modes:

AIR / C₂H₂ Flame mode with AIR / C₂H₂ burner: Install AIR / C₂H₂ burner on burner assembly. Open all gas and oxidant lines. Power on the system, gas box performs the default checks and found OK, IGNITION LED comes on indicating gas box is ready for ignition. Press ignition key switch this initiates the AIR /C₂H₂ flame sequence. First glow plug filament is heated for about 3sec. Then ignition solenoid is made ON releasing Acetylene gas jet. When this gas passes through red-hot filament it gets ignited and pilot flame comes on. This gas ignited with the pilot flame [3]. After three sec delay, ignition solenoid and filament are made off. The flame detector and default sense sequence continuously monitors the flame and fault conditions. Any fault condition automatically initiates the following shut off sequence.

N₂O / C₂H₂ FLAME mode with N₂O / C₂H₂ burner: Install N₂O / C₂H₂ burner on burner assembly. Open all gas and oxidant lines. Power on the system. Gas box performs the default checks and found OK, IGNITION LED blinks for 40 sec and gets on indicating gas box is ready for ignition. When N₂O / C₂H₂ key is pressed boost solenoid is switched on. After 3 sec delay N₂O solenoid and Air solenoid are switched on simultaneously. N₂O gas is used as oxidant instead of air in this mode [2].

After the boosted N₂O flame is ignited the flame detects and defaults senses sequence continuously monitors the fault condition. Any fault condition automatically initiated the shut off sequence is initiated.

Interfacing of Auto gas control unit with AAS mainly consists of microprocessor 8085, latch, EPROM, RAM, Decoder and two PPI IC's interfaced through a euro connector as shown in the figure 2.

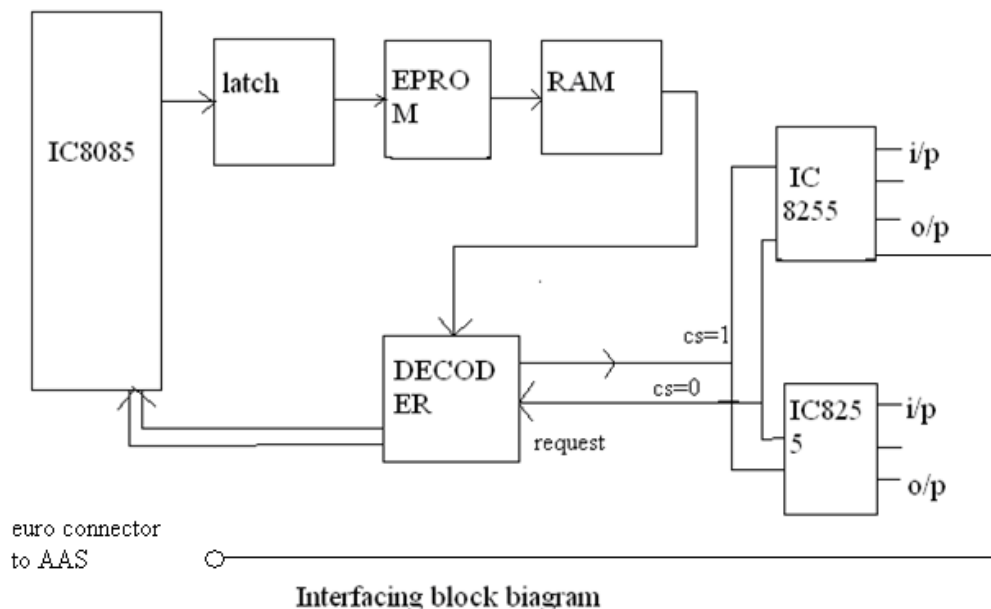



Figure 2: Block diagram of interfacing ASS and AGC

Operation of AAS through Software

- Switch on Stabilizer.
- Switch on Air Compressor.
- Switch on AAS Unit.
- Switch on PC and Monitor.
- Desktop Screen appears as shown in screen 1.
- Double Click on AAS Icon. The AAS Operating System Screen appears on Desktop as shown in screen 2.
- Click on POWER ON/OFF Icon. AAS system gets ON.
- Place the lamp of interest in segment and align to optical path. Switch on the Corresponding Lamp switch on AAS system. Click on the elements in the elements List corresponding settings of that element automatically gets loaded. Click on the corresponding Lamp No on TOOL BAR. Lamp gets ON with the specified current.
- In case of Auto Turret click on Lamp Turret. Click on the lamp number to be alignment to optical path. For example if Lamp 3 is to be aligned to optical path, click on UncodedLamp. Turret rotates and aligns the corresponding Lamp to optical path, and lamp gets ON with specified current.
- Click on the Peak Search Icon as shown in tool bar to search the analytical peak of the element and align. A dialogue Box appears on the screen as shown in screen 4. Click on YES Button. System proceeds to search Analytical peak and aligns to the peak wavelength. Analytical peak spectrum and HCL signal are displayed. Maximize the HCL signal with the 3 adjustable knurled screws provided on Lamp Segment. If NO button is clicked, system stops peak searching.
- By clicking on increasing or decreasing arrow keys [] provided for EHT setting, adjust the HCL signal to be in-between 3.0V to 3.5V.
- After the peak search completed of a particular element (copper) the screen appears as shown in the screen 5.
- Click on analysis (A) icon on the Tool Bar, and the screen appears as shown in the screen 6.
- Click on READ icon as shown in TOOL BAR.
- Ensure the required Burner i.e., AIR / C₂H₂ or N₂O /C₂H₂ is placed on burner assembly.
- Open the Acetylene Cylinder [C₂H₂] with Cylinder opener. Ensure that line pressure is 1Kg/cm² and the cylinder pressure is greater than 100 PSI.
- Ensure that the Air Pressure is 5 Kg / Cm² or more for Auto Gas Control Unit and 2.5 Kg / Cm² for Manual Gas Control unit.
- In case of N₂O / Acetylene flame, the N₂O Line Pressure should be same as the Air Pressure i.e., 5 Kg/cm² for Auto Gas Control unit and 2.5 Kg/cm² for Manual Gas Control unit.
- Ensure proper alignment of the light beam on to the burner centre. Proper alignment of burner can be achieved with the three knobs provided on the burner assembly for Horizontal, Vertical, and angular movements.

- After clearing all the default checks gas control box displays IGNITION LED ON indicating the system is ready for ignition. In case any fault is detected, corresponding default LED is ON. Clear the corresponding fault.
- Press the IGNITION button, which starts the Automatic sequence of Flame ignition, by first releasing the pilot flame, then releasing the C_2H_2 gas through Fuel flow meter onto the burner head, lighting the flame and withdrawal of pilot flame. Ensure HCL Signal Energy to be in- between 3.0V to 3.5V after flame is established, by adjusting EHT.
- Put the capillary tube in 1st standard, wait for 5 seconds and click the READ Icon of TOOL BAR of screen. System will display the CONC & ABS readings of 1st standard.
- Put the capillary tube in distilled water for few seconds, feed the 2nd standard, wait for 5 seconds and click the READ Icon on the screen. System will display the readings of the 2nd standard.
- Put the Capillary tube in distilled water for few seconds, feed the 3rd standard, wait for 5 seconds and click the READ Icon on the screen. System will display the readings of the 3rd standard.
- Put the Capillary tube in distilled water. Standard readings (Abs, %T, CONC.) will be displayed as shown in the screen 8.
- Click the GRAPH Icon to view the Calibration Graph i.e., Concentration V/s Absorbance as shown in screen 9.
- Come out from the graph by clicking on “CLOSE” button. Click the Sample Icon on the screen. System will prompt you to enter number of samples to be analyzed as shown in screen 10. Enter the No. of samples to be analyzed and press ENTER key. Enter the Names or Labels of samples to be analyzed and press the ENTER key continuously. Names or Labels entered will be displayed.
- Feed the 1st standard, wait for 5 seconds and click READ Icon on the screen. System will display the CONC readings of 1st standard as unknown sample readings.
- Now feed Unknown Sample, wait for 5 seconds and click READ Icon. System will display the CONC readings of this sample.
- Feed 2nd Unknown Sample, wait for 5 seconds and click the READ Icon. System will display the CONC readings of this sample.
- Follow the above procedure till your samples are completed. After completing the sample analysis feed the distilled water for at least 2-3 minutes.
- In case of Auto Gas Control Unit, close the Acetylene Gas Cylinder and press SHUTOFF Key. The system shuts off the flame automatically.
- For Saving the Results click on SAVE Icon of TOOLBAR as shown in the screen 12. System will prompt you to enter the Results file name. After typing the File Name, Press ENTER key. The Results are stored in this file.

Result

The figure 3 shows the result analysis of the selected element i.e., Copper. It provides the Wavelength, Lamp current and other parameters related to the element selected.

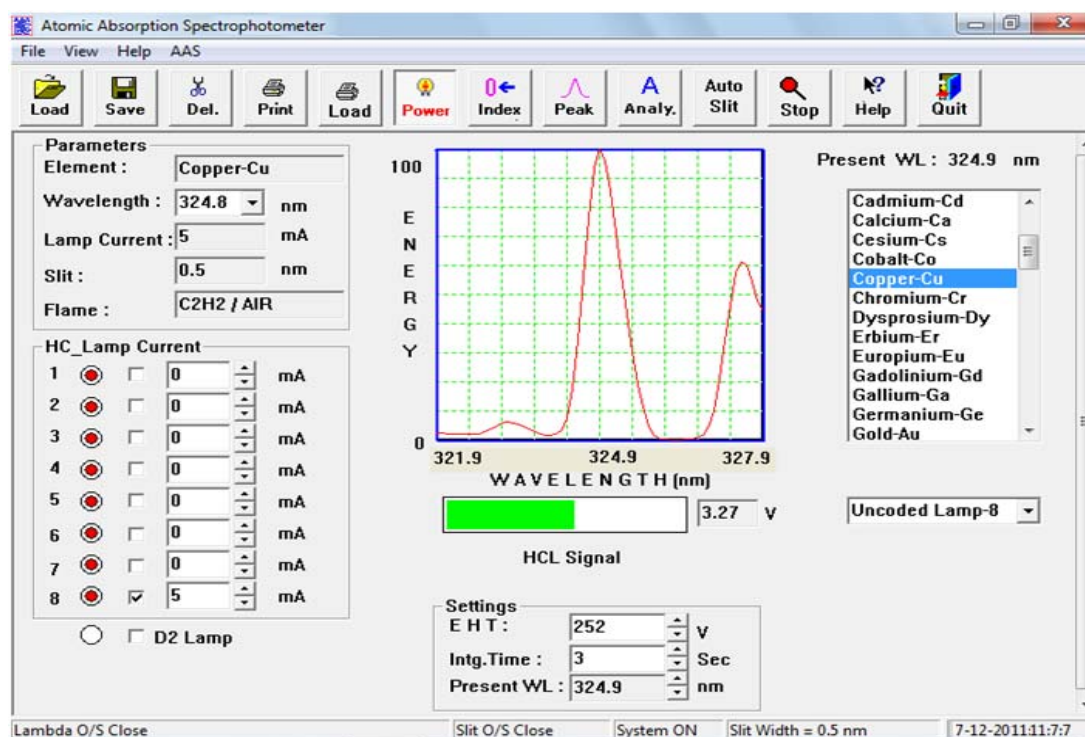

Applications of AAS

Food: This is a valuable instrument in measurement of vitamins, Amino acids and many other compounds or elements directly related to food substance.

Medical: In analysis of enzymes, hormones, steroids, alkaloids and habituates can be carried out. It is most useful to physician in diagnosis of diabetes. Kidney damages, AIDS and numerous other alignments.

Pharmaceuticals: It provides spectra for detection of several compounds when interfacing substances are represent [2].

Agriculture: In identification and quantitative determination of pesticides, insecticides etc. This analysis enables scientists to safe guard public health by providing information about the effect of chemicals used in the control of crop pest.

Colorimeter: In identification of all metallic elements in wide variety of substances. A large variety of organic compounds can also be similarity determined.

Forensic Sciences: This can be of great service in the searching of new drugs for

toxicological studies, for investigating complicated matters and detection of illegal stimulants and depressants on animals.

Conclusion

From the above report on the project it may be concluded that the spectrophotometer is a very useful device for getting the exact characteristics of sample, which is usually in the form of liquid within the electromagnetic spectrum of light, for any different wavelength selection. Previously when this unit is operated manually consumed lot of time. But at present as the software field is developed in such way like that making use of that can operate any instrument of kind PC achieves instrument controls like gas control, wavelength, lamp current etc., The data analysis and report making is done in PC, including selection of instrument parameters like wavelength, lamp current selection and EHT to PMT at various wavelengths.

The software is user friendly windows based interfacing using menus/function keys, prompts and error messages, enabling ease of operation information is represented in easy read menus. In most cases recommended values are filled-in.

Acknowledgement

The authors would like to thank:

The Head of the Department, Professor Thanam P, Mtech, MIEEE. The Project Guides Professor Datthathri, Associate Professor in Department of Electronics and Communication Engineering & Mr.Vinod Auhuja, Associate Professor in Department of Electronics and Communication Engineering. The Project Supervisors Ms.T.Lavanya, Associate Professor and Mrs.Devika, Associate Professor of Hyderabad Institute of Technology and Management, Hyderabad for their constant help and support all the time

Bibliography

- [1] Welz, M. Sperling (1999), Atomic Absorption Spectrometry, Wiley-VCH, Weinheim, Germany,.
- [2] Walsh (1955), The application of atomic absorption spectra to chemical analysis, Spectrochim. Acta 7: 108-117.
- [3] J.A.C. Broekaert (1998), Analytical Atomic Spectrometry with Flames and Plasmas, 3rd Edition, Wiley-VCH, Weinheim, Germany.
- [4] B.V. L'vov (1984), Twenty-five years of furnace atomic absorption spectroscopy, Spectrochim. Acta Part B, 39: 149-157.
- [5] B.V. L'vov (2005), Fifty years of atomic absorption spectrometry; J. Anal. Chem., 60: 382-392.
- [6] H. Massmann (1968), Vergleich von Atom absorption und Atom fluoreszenz in der Graphitküvette, Spectrochim. Acta Part B, 23: 215-226.

- [7] W. Slavin, D.C. Manning, G.R. Carnrick (1981), The stabilized temperature platform furnace, *At. Spectrosc.* 2: 137-145.
- [8] H. Becker-Ross, S. Florek, U. Heitmann, R. Weisse (1996), Influence of the spectral bandwidth of the spectrometer on the sensitivity using continuum source AAS, *Fresenius J. Anal. Chem.* 355: 300-303.
- [9] J.M. Harnly (1986), Multielement atomic absorption with a continuum source, *Anal. Chem.* 58: 933A-943A.