

Analysis of AC Transmission System using Interline Power Flow Controller for damping of low frequency oscillations with PI Controller

Ch.Venkata Krishna Reddy

Assistant Professor, CBIT, Hyderabad
India.

K.Krishna Veni

Professor, CBIT, Hyderabad
India.

G.Tulasi Ram Das

Professor, JNTUH, Hyderabad
India.

Abstract

The new series – series FACTS device Interline Power Flow Controller (IPFC) is a voltage source converter based Flexible AC Transmission System (FACTS) controller for series compensation with the unique capability of power flow management among the multiple transmission lines in transmission system. Due to disturbance, the electromechanical oscillations will present in the transmission system and these oscillations should damp out using IPFC. The performance of considered IEEE 14 bus system is analyzed in terms of electro mechanical oscillations using IPFC. The conventional Proportional Integral controller with Interline Power Flow Controller (IPFC) is used to damp oscillations. This analysis is carried out using MATLAB/Simulink for different fault conditions.

Keywords: Flexible AC Transmission System (FACTS), Interline Power Flow Controller (IPFC), Voltage Source Converter (VSC), PI Controller, Stability.

INTRODUCTION

Transient stability analysis gained importance, in terms of maintaining stability through application of advanced FACTS devices and controls. The ability of the power system is concerned when extreme disturbances are subjected to it. The consequential system is then influenced by the nonlinear power-angle correlation [1].

The system's initial operating state and the severity of the disturbance decides the transient stability of the system generally, the system is modified when the post-disturbance steady-state operation differs from that of its prior disturbance. Instability is generally in the form of aperiodic angular partition because of inadequate synchronizing torque [2]. However, in extensive power systems, transient instability may not generally occur as first swing instability connected with a single mode; it could be an effect of superposition of a slow inter-area and a local-plant swing modes that causes a large excursion of rotor angle ahead of the first swing [1].

Generally, the transient stability can be studied in 3 to 5 seconds, after the disturbance has occurred. For extremely large systems having dominant inter-area swings this may take up to 10-20 seconds [2].

The combined Flexible Alternating Current Transmission System (FACTS) devices like UPFC, IPFC and so forth have been utilized to damp the oscillations apart from its primary utilization of steady state control. Such devices were installed

on transmission lines conversely to the devices like PID, PSS etc. [3].

In this work, the FACTS device namely IPFC is used to damp power oscillations with the advantages of individual control of each transmission line. This IPFC is located between buses 1 and 12 of IEEE 14 bus system. The IPFC is utilized to damp the power oscillations of IEEE 14 bus power network for different faults and are further applied between buses 7 and 8 using PI controller.

In this work, the design and performance of PI based IPFC have been investigated for IEEE 14 bus multi-machine power system to enhance damping oscillations. The effects of different faults on the network are presented and investigations are carried out.

SYSTEM UNDER STUDY

IEEE 14 bus system considered for analysis is shown in Fig.1. This system includes five T-G units with IEEE type-1 exciters, 14 buses, three transformers and twenty AC transmission lines. This system has 11 loads totaling 259 MW and 81.3 Mvar. The data for the generator's exciters was selected from [4]. Bus 1 is selected as slack bus. The generator G1 is considered as reference. The three synchronous compensators are considered as generators to meet the demand of the real power by loads. The generators are modeled with both P and Q limits as standard PV buses, loads are considered as constant PQ loads. The considered base values for this system are 100 MVA and 100KV [4].

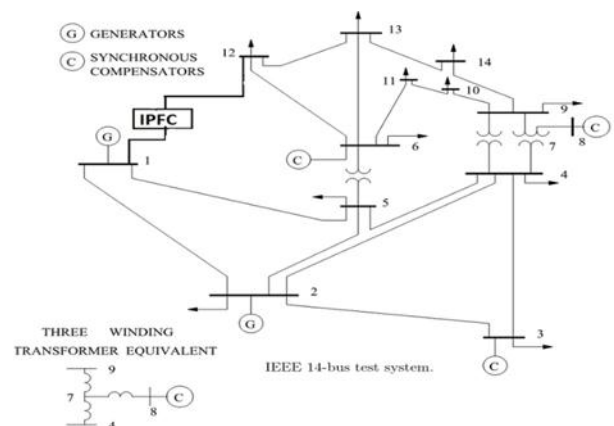

Figure 1. IEEE 14 Bus Power Network under study with IPFC

INTERLINE POWER FLOWCONTROLLER FOR STABILITY

Rotor angle stability deals with the ability of interconnected synchronous machine of a power to remain in synchronous stage during disturbance and normal operating condition. It depends on the capability to keep equilibrium between electromagnetic torque and mechanical torque of every synchronous machine in the system. The increasing of angular swings of generators leading to their loss of synchronism with other generators is called rotor angle instability [1].

The speed of generators and motors is easily controlled by power electronic devices. As a result it can control the rotor angle stability. IPFC is one of the power electronics devices which contain converters within DC link. Therefore it can allow reactive and active power to flow in the multiline simultaneously; the problem of oscillation is damped out by dc link [5, 6]. The DC link parameters of IPFC are $V_{dc} = 1.4e^5$ and $C_{dc} = 1000e^{-3}$. The controller structure with IPFC for rotor angle stability is shown in Fig. 2. The MATLAB/SIMULINK diagram of IEEE 14 bus system using IPFC with fault is shown in Fig. 3.

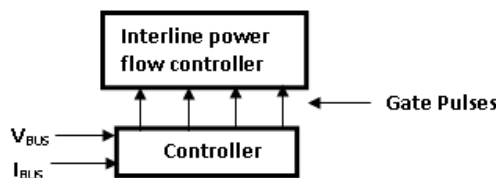

Figure 2. Controller structure with IPFC.

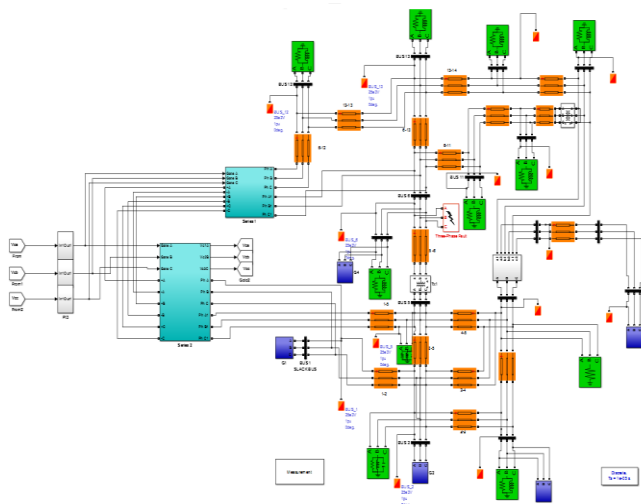

Figure 3. MATLAB/SIMULINK diagram of IEEE 14 bus system using IPFC with fault.

PI CONTROLLER

The control strategy of PI controller is shown Fig. 4. Here the V_{ref} is compared with corresponding bus voltage V_{ph-ph} and the error obtained, V_{error} , is applied to PI control block, Here the

limiter output V^* is applied to the PWM generator. The PWM generator output is compared with the carrier signal using a comparator, to get desired gate pulses which are used for IPFC[7,8]. The MATLAB / SIMULINK diagram of conventional PI controller is shown in Fig. 5. The PI controlled parameters are $K_p = 2.3475$ and $K_i = 0.3399$.

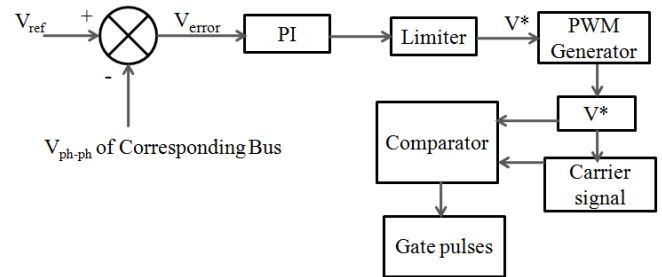

Figure 4. Block diagram for control strategy for PI controller.

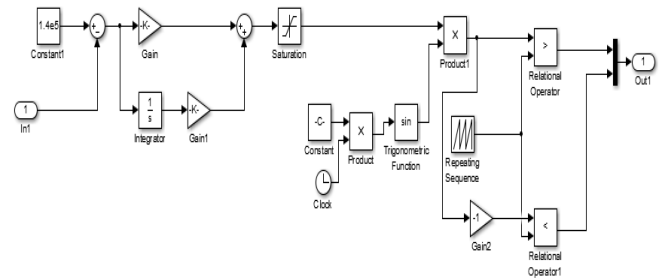

Figure 5. MATLAB/SIMULINK diagram of PI controller.

MATLAB SIMULATION RESULTS

Digital Simulation studies are carried out using MATLAB. IEEE 14 bus system is considered to study the effectiveness of IPFC in damping the oscillation for different disturbances such as i) LG fault ii) LLG fault iii) LLLG fault [9]. The power (load) angle curves in degrees vs. time are obtained for LG, LLG and LLLG faults without IPFC using PI controller are shown in Fig. 6,7and 8 respectively. The power (load) angle curves in degrees vs. time are obtained for LG, LLG and LLLG faults with IPFC using PI controller are shown in Fig. 9,10 and 11 respectively. The response curve of rotor speed are obtained for LG, LLG and LLLG faults with IPFC using PI controller are shown in Fig. 12,13 and 14 respectively. The response curve of rotor speed are obtained for LG, LLG and LLLG faults with IPFC using PI controller are shown in Fig. 15,16 and 17 respectively. Also the analysis was carried out for other generators for different faults in terms of rotor angle and rotor speed with respect to settling time and amplitude of oscillations and are listed in Table 1, 2 and 3 for LG, LLG and LLLG faults without IPFC respectively. Similarly the analysis was carried out for other generators for different faults in terms of rotor angle and rotor speed with respect to settling time and amplitude of oscillations and are listed in Table 4, 5 and 6 for LG, LLG and LLLG faults with IPFC using PI controller respectively.

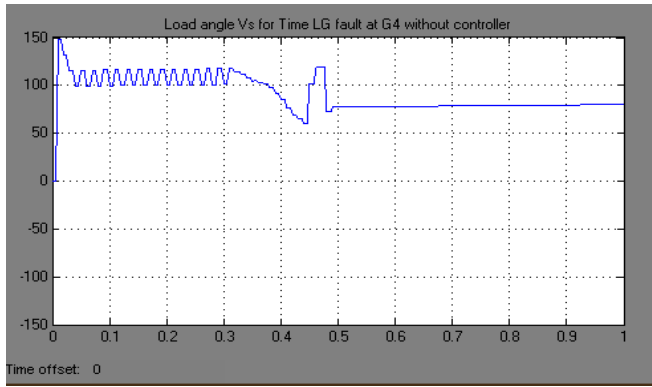

Figure 6. Load angle Vs time, LG fault at G4 without controller

From Fig.6 it is manifest that LG fault applied between 0.3 and 0.5 secs without controller and overshoot is around 50% in amplitude and settling time is of 0.48secs is obtained for a applied set point of 100. The response is varied in terms of transient response and settling time.

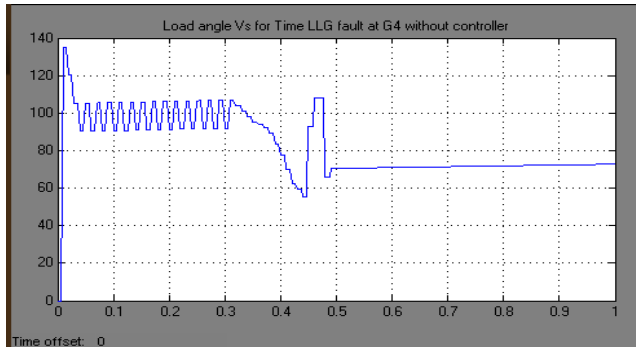

Figure 7. Load angle Vs time, LLG fault at G4 without controller

From Fig.7 it is evident that LLG fault applied between 0.3 and 0.5 secs without controller and overshoot is around 38% in amplitude and settling time is of 0.48secs is obtained for the set point of 100 is applied. The response is largely varied in terms of transient response (overshoot and undershoot) and settling time.

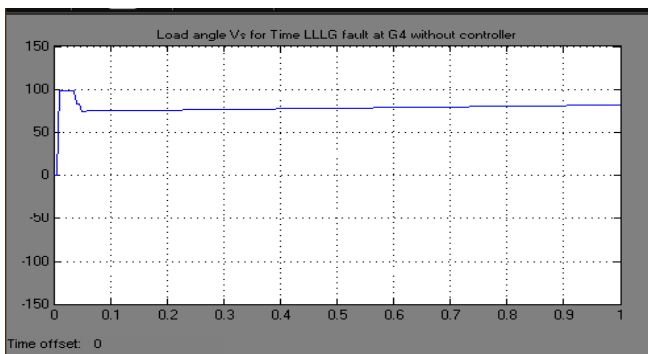

Figure 8. Load angle Vs time, LLLG fault at G4 without controller

From Fig.8 it is evident that LLLG fault applied between 0.3 and 0.5 secs without controller and overshoot is around 25% in amplitude and settling time is of 0.05secs is obtained for the set point of 100 is applied. The response is not affected for transient response (overshoot and undershoot) and settling time.

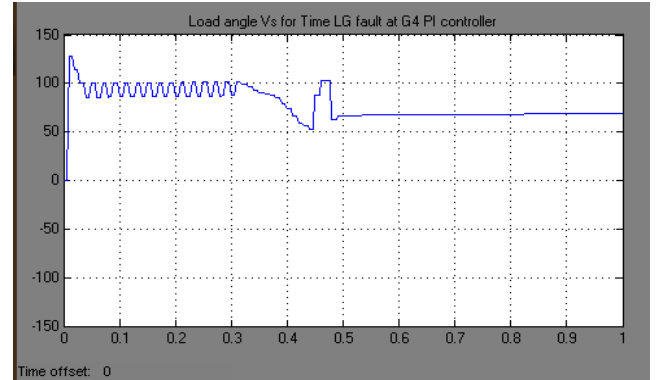

Figure 9. Load angle Vs time, LG fault at G4 with IPFC using PI Controller

From Fig.9 it is apparent that the LG fault applied between 0.3 and 0.5 secs with controller and the overshoot is around 25% in amplitude and settling time is of 0.48secs is obtained for the set point of 100 is applied. The response is varied in terms of transient response (overshoot and undershoot) and settling time.

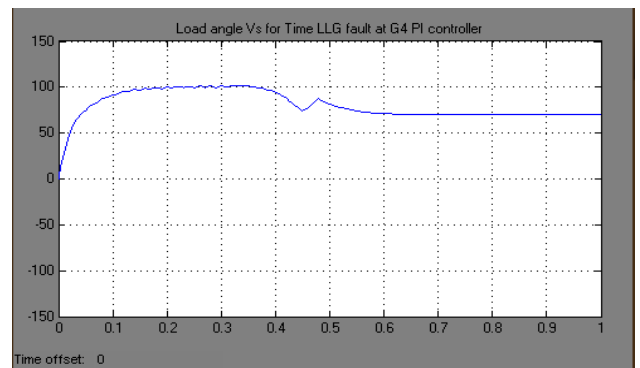

Figure 10. Load angle Vs time, LLG fault at G4 with IPFC using PI Controller

From Fig.10, it is evident that LLG fault applied between 0.3 and 0.5 secs with controller and the overshoot of 10% is reduced in amplitude and settling time is of 0.6 secs is obtained for the set point of 100 is applied. The response has a delay time of 0.1sec of response and settling time.

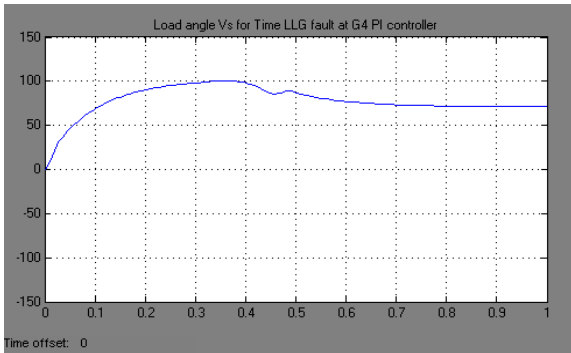

Figure 11. Load angle Vs time, LLLG fault at G4 with IPFC using PI Controller

From Fig.11 it is manifest that LLLG fault applied between 0.3 and 0.5 secs with controller and overshoot is reduced in percentage of amplitude and settling time is of 0.12secs is obtained for the set point of 100 is applied. The response has a delay time of 0.3sec of response and settling time.

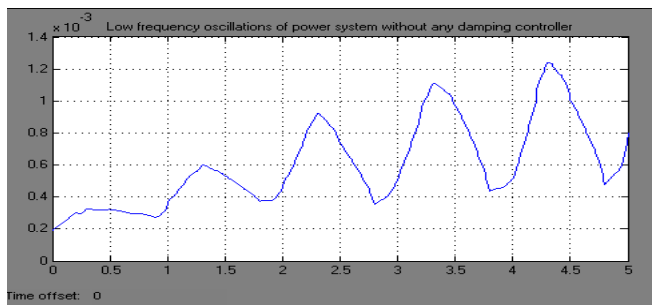

Figure 12. Rotor speed Vs time, LG fault at G4 without IPFC

From Fig.12 it is evident that LG fault applied between 0.3 and 0.5 secs without controller and graph increases exponentially and not converged, so the response seems to be unstable

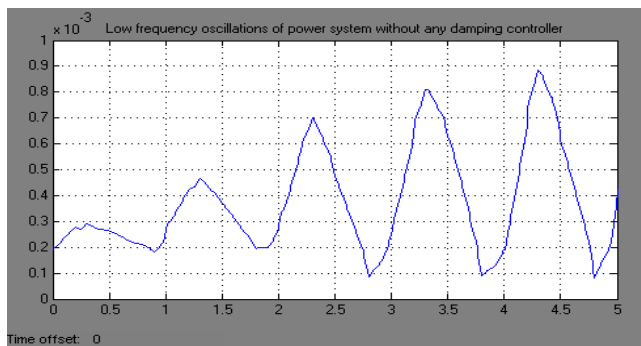

Figure 13. Rotor speed Vs time, LLLG fault at G4 without IPFC

From Fig.13 it is apparent that with LLLG fault applied between 0.3 and 0.5 secs without controller and graph increases exponentially and not converged, so the response seems to be unstable.

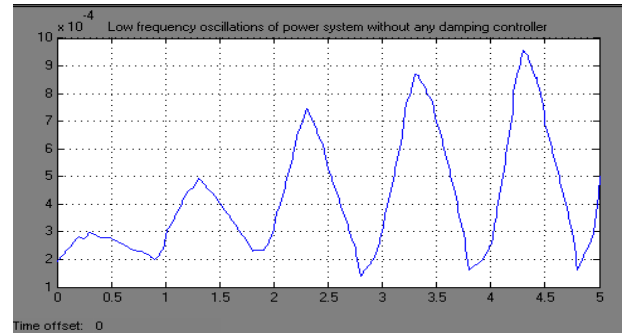

Figure 14. Rotor speed Vs time, LLLG fault at G4 without IPFC

From Fig.14 it is evident that with LLLG fault applied between 0.3 and 0.5 secs without controller and graph increases exponentially and not converged, so the response seems to be more unstable

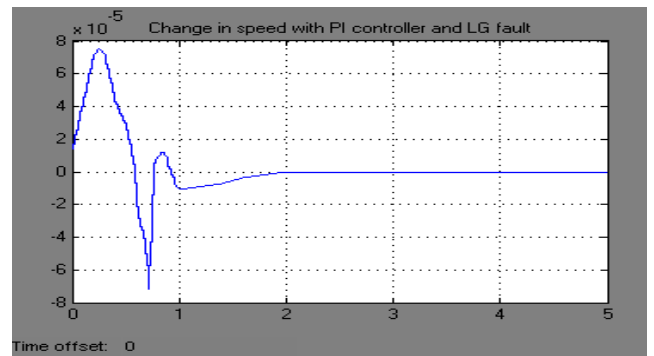

Figure 15. Rotor Speed Vs time, LG fault at G4 with IPFC using PI Controller

From Fig.15, it is manifest that the LG fault is applied between 0.5 and 1sec with controller and first overshoot of $7e-5$; undershoot of $-7e-5$ in amplitude and settling time of 1.9sec. When compared to without damping controller the response with PI controller is stable and improved.

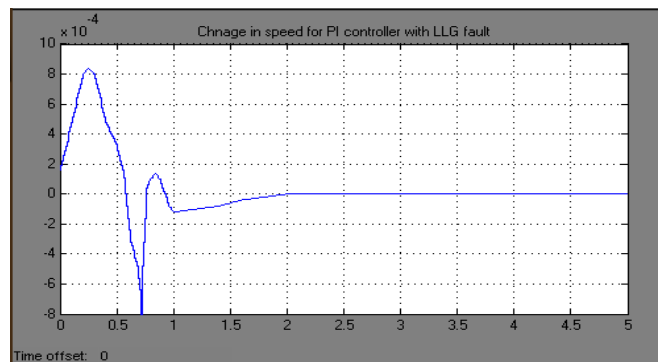

Figure 16. Rotor Speed Vs time, LLLG fault at G4 with IPFC using PI Controller

From Fig.16, it is apparent that LLG fault applied between 0.5 and 1 sec and the first overshoot of $8.25e-4$; undershoot of $-8.25e-4$ in amplitude and settling time of 2 sec. When compared to without damping controller the response with PI controller for LLG fault is improved.

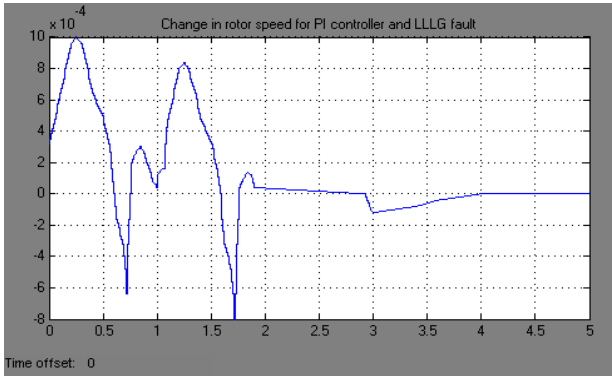

Figure 17. Rotor Speed Vs time, LLLG fault at G4 with IPFC using PI Controller

From Fig.17, it is evident that the LLLG fault applied between 0.5 and 1sec with controller and the first overshoot of $10e-4$; undershoot of $-8.25e-4$ in amplitude and settling time of 4 sec. When compared to without damping controller the response with PI controller for LLG fault is improved.

Table 1: Results obtained for all generators when LG fault (0.5 to 2 secs) applied at G4 without IPFC

Generator No	Rotor angle		Rotor speed	
	Settling time (sec)	Amplitude of oscillations (degrees)	Settling time (sec)	Amplitude of oscillations (degrees)
1	1.2	120	2.5	$4.5e-4$
2	1.05	110	3.2	$5.8e-4$
3	1.1	56	2.1	$4.5e-4$
4	0.5	50	5	$8.1e-4$
5	1.3	65	6.2	$2.5e-4$

The results obtained for rotor angle and rotor speed versus time (sec) at G4 for LG fault applied between 0.5 and 2 secs without IPFC are tabulated in Table 1 for all generators. From Table 1 it is noticed that, the rotor speed and rotor angle are affected in terms of the amplitude and settling time. The rotor speed is very high in magnitude and settling time.

Table 2: Results obtained for all generators when LLG fault (0.5 to 2 secs) applied at G4 without IPFC

Generator No	Rotor angle		Rotor speed	
	Settling time (sec)	Amplitude of oscillations (degrees)	Settling time (sec)	Amplitude of oscillations (degrees)
1	1.75	45	2.5	$3.25e-3$
2	1.82	89	3.2	$0.5e-3$
3	1.23	92	0.95	$5.28e-3$
4	0.49	35	4.5	$1.25e-3$
5	0.8	112	1.1	$6.42e-3$

The results obtained for rotor angle and rotor speed versus time (sec) at G4 for LLG fault applied between 0.5 and 2 secs without IPFC are tabulated in Table 2 for all generators. From Table 2 it is noticed that, the rotor speed and rotor angle are affected in terms of amplitude and settling time. The rotor speed is comparatively less in magnitude and settling time.

Table 3: Results obtained for all generators when LLLG fault (0.5 to 2 secs) applied at G4 without IPFC

Generator No	Rotor angle		Rotor speed	
	Settling time (sec)	Amplitude of oscillations (degrees)	Settling time (sec)	Amplitude of oscillations (degrees)
1	2.75	56	5.5	$1.15e-3$
2	3.28	78	2.2	$2.05e-3$
3	3.23	72	0.95	$2.28e-3$
4	0.8	63	1.65	$0.9e-3$
5	1.23	102	1.95	$2.28e-3$

The results obtained for rotor angle and rotor speed versus time (sec) at G4 for LLLG fault applied between 0.5 and 2 secs without IPFC are tabulated in Table 3 for all generators. From Table 3 it is noticed that, the rotor speed and rotor angle are affected in terms of amplitude and settling time. The rotor speed and rotor angle are less increased in magnitude and settling time.

Table 4: Results obtained for all generators when LG fault (0.5 to 2 secs) applied at G4 with IPFC using PI Controller

Generator No	Rotor angle		Rotor speed	
	Settling time (sec)	Amplitude of oscillations (degrees)	Settling time (sec)	Amplitude of oscillations (degrees)
1	1.18	72	0.95	$4.0e-4$
2	1.00	89	3.2	$0.5e-5$
3	1.08	41	2.25	$1.15e-5$
4	0.48	28	2	$7.8e-5$
5	1.23	62	0.95	$5.28e-5$

The results obtained for rotor angle and rotor speed versus time (sec) at G4 for LG fault applied between 0.5 and 2 secs using PI controller with IPFC are tabulated in Table 4 for all generators. From Table 4 it is noticed that, the rotor speed and rotor angle are increased in terms of amplitude for rotor angle and settling time in terms of rotor speed.

Table 5: Results obtained for all generators when LLG fault (0.5 to 2 secs) applied at G4 with IPFC using PI Controller

Generator No	Rotor angle		Rotor speed	
	Settling time (sec)	Amplitude of oscillations (degrees)	Settling time (sec)	Amplitude of oscillations (degrees)
1	1.25	50	2.2	6.58e-5
2	1.80	85	0.96	4.2e-5
3	1.25	60	1	3.2e-5
4	0.6	32	2	7.8e-5
5	1.14	101	1.05	1.9e-5

The results obtained for rotor angle and rotor speed versus time (sec) at G4 for LLG fault applied between 0.5 and 2 secs using PI controller are listed in Table 5 for all the generators. From Table 5 it is observed that, the rotor speed and rotor angle are affected in terms of amplitude for rotor angle and settling time in terms of rotor speed.

Table 6: Results obtained for all generators when LLLG fault (0.5 to 2 secs) applied at G4 with IPFC using PI Controller

Generator No	Rotor angle		Rotor speed	
	Settling time (sec)	Amplitude of oscillations (degrees)	Settling time (sec)	Amplitude of oscillations (degrees)
1	1.23	54	0.95	1.05e-3
2	1.82	75	2.1	0.5e-5
3	1.62	41	1.00	1.15e-5
4	0.82	38	4	10e-4
5	0.8	62	1.1	3.1e-3

The results obtained for rotor angle and rotor speed versus time (sec) at G4 for LLLG fault applied between 0.5 and 2 secs using PI controller are listed in Table 6 for all generators. From Table 6, it is observed that the rotor speed are affected in terms of amplitude and settling time, whereas in rotor angle the amplitude and settling time are improved.

Hence IPFC provides control in both amplitude of oscillations with respect to load angle, rotor speed and settling times for different fault cases.

CONCLUSION

The load angle of the machine increases during faulted period and it decreases during post fault period. The settling time for the load angle is low for the system with IPFC for balanced and unbalanced faults. The speed of the machine increases during faulted period and it decreases during post fault period. The settling time for the speed is low for the system with IPFC for balanced and unbalanced faults. Hence, it is inferred that the IPFC controller provides better damping of load angle and speed deviations.

REFERENCES

- [1] P. Kundur et al., "Definition and classification of power system stability IEEE/CIGRE joint task force on stability terms and definitions," in IEEE Transactions on Power Systems, vol. 19, no. 3, pp. 1387-1401, Aug. 2004.
- [2] G. K. Morison, B. Gao, and P. Kundur, "Voltage stability analysis using static and dynamic approaches," IEEE Trans. Power Systems, vol. 8, pp. 1159-1171, Aug. 1993.
- [3] R. H. Adware, P. P. Jagtap and J. B. Helonde, "Power System Oscillations Damping Using UPFC Damping Controller," 3rd International Conference on Emerging Trends in Engineering and Technology (ICETET), Goa, 2010, pp. 340-344.
- [4] Sameh Kamel Mena Kods, Claudio A. Canizares "Modeling and simulation of IEEE 14 bus system with facts controllers," Technical report 2003; 3.
- [5] F. Milano. "Power System Modeling and Scripting," Power Systems series, Springer, 2010, doi:10.1007/978-3-642-13669-6.
- [6] G. Hingorani and L. Gyugi, "Understanding FACTS: Concepts and Technology of Flexible AC Transmission Systems," IEEE Press, 1999.
- [7] Parvathy S., K.C. Sindhu Thampatty, Dynamic Modeling and Control of UPFC for Power Flow Control, Procedia Technology, Volume 21, 2015, Pages 581-588, ISSN 2212-0173, <http://dx.doi.org/10.1016/j.protcy.2015.10.061>.
- [8] R. Navabi, R. Etemad and H. A. Shayanfar, "Self Tuning Fuzzy PI Controller for UPFC to Improve Power System Stability Optimized by Ant Colony Method," 2010 Asia-Pacific Power and Energy Engineering Conference, Chengdu, 2010, pp. 1-5.
- [9] Paul M. Anderson, "Analysis of Unsymmetrical Faults: Three Component Method," in Analysis of Faulted Power Systems, 1, Wiley-IEEE Press, 1995, pp.36-70.